



EV9618-02

OCS² Filter Cartridge

Delivers premium quality water for office coffee applications



OCS² Replacement Cartridge:
EV9618-02

BENEFITS

New and improved Micro-Pure II media with AgION™ antimicrobial protection inhibits any potential bacterial growth

Provides clear, fresh, premium quality ingredient water for consistently great tasting coffee and beverages

Everpure's unique filter blend using activated carbon reduces chlorine taste and odor and other offensive contaminants

Saves energy by reducing scale build-up. Proportioned scale inhibitor feed dramatically prevents limescale from forming in brewing equipment

Precoat submicron technology reduces dirt and particles as small as 1/2 micron in size

Reduces health contaminants such as asbestos fibers and Cryptosporidium and Giardia cysts

Sanitary cartridge replacement is simple, quick and clean. Internal filter parts are never exposed to handling or contamination

INSTALLATION TIPS

- Never use saddle valve for connection
- Use 3/8" water line
- Install vertically with cartridge hanging down
- Allow 2-1/2" clearance below the cartridge for easy cartridge replacement
- Flush OCS cartridge by running water through filter for three minutes at full flow

OPERATION TIPS

- Change cartridges on a regular 6 month preventative maintenance program
- Change cartridges when capacity is reached or when pressure falls below 10 psi
- Service flow rate must not exceed 0.5 gpm
- Always flush the filter cartridge at time of installation and cartridge change

APPLICATION/SIZING

- For coffee service applications
- For low flow, low volume brewers
- Rated Capacity: 1,500 gallons (5,678L) or 3,000 pots

OCS² Filter Cartridge

SPECIFICATIONS

Overall Dimensions:

10.25"H x 3.25"Diameter

Service Flow Rate:

Maximum 0.5 gpm (1.9 Lpm)

Rated Capacity: 1,500 gallons

Pressure Requirements:

10 - 125 psi (0.7 - 8.6 bar), non-shock

Maximum Temperature:

35 - 100°F (2 - 38°C)

No electrical connection required

The contaminants or other substances removed or reduced by this drinking water system are not necessarily in your water. Do not use with water that is microbiologically unsafe or of unknown quality without adequate disinfection before or after the system.

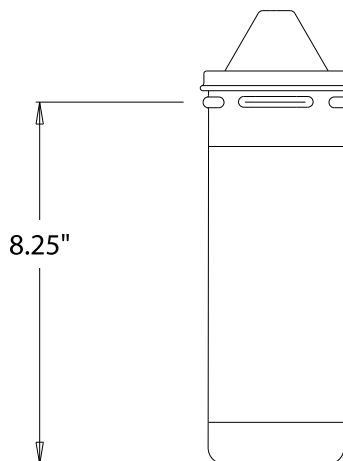

WARRANTY

Everpure water treatment systems (excluding replaceable elements) are covered by a limited warranty against defects in material and workmanship for a period of five years after date of purchase. Everpure replaceable elements (filter cartridges and water treatment cartridges) are covered by a limited warranty against defects in material and workmanship for a period of one year after date of purchase. See printed warranty for details. Everpure will provide a copy of the warranty upon request.

EVERPURE®

Worldwide Headquarters:
EVERPURE, LLC
1040 Muirfield Drive
Hanover Park, Illinois 60133
Toll Free (800) 323-7873
Tel (630) 307-3000
Fax (630) 307-3030
<http://www.everpure.com>

In Europe:
Pentair Water Belgium B.V./B.A.
Industriepark Wolfstee
Toekomstlaan 30
B-2200 Herentals
BELGIUM
TEL: +32.(0).14.283.500
FAX: +32.(0).14.283.505

In Japan:
Hashimoto MN Bldg. 7F
3-25-1 Hashimoto Sagami-hara-Shi
Kanagawa 229-1103
JAPAN
TEL: 81.(0)42.775.3011
FAX: 81.(0)42.775.3015